

Flow divider with independent phase correction and anticavitation valves for each element

### Code:

9V	NN	M	CC
----	----	---	----

9V	Flow Divider Typology
NN	Number of elements
M	Code of setting range of the valves
CC	Displacement Code

TABLE "M"	
A	10÷ 105 bar
B	70÷ 210 bar
C	140÷ 350 bar

**Example:** Flow divider with two elements (same displacement) :  
XV-3V / 38 x 2 with valve 10 ÷ 105 bar

9V	02	A	78
----	----	---	----

**Example:** Flow Divider with 4 elements with different displacement (max 7):  
XV-3V / 21+51+51+70 with valve 70 ÷ 210 bar

9V	04	B	70	81	81	86
----	----	---	----	----	----	----

**NOTE:** to define codes for flow dividers with more than 7 different displacement, please contact our sales department.

### Table: 1

Displacem. Cm <sup>3</sup> /rev	CC Code	Max Pressure bar	One element flow rate l/min		
			MIN	RECOMMENDED	MAX
15	66	300	18	27	37,5
18	68	300	21,5	32,5	45
21	70	280	25	38	52,5
27	72	250	32,5	48	67,5
32	74	250	38	57	80
38	78	250	41	60	91
43	79	250	43	64,5	99
47	80	230	47	70,5	108
51	81	230	51	76,5	117
54	82	230	54	81	124
61	83	230	56	82	126
64	85	210	57	83	128
70	86	200	63	91	140
74	87	180	66,5	96	148
90	89	150	81	117	180

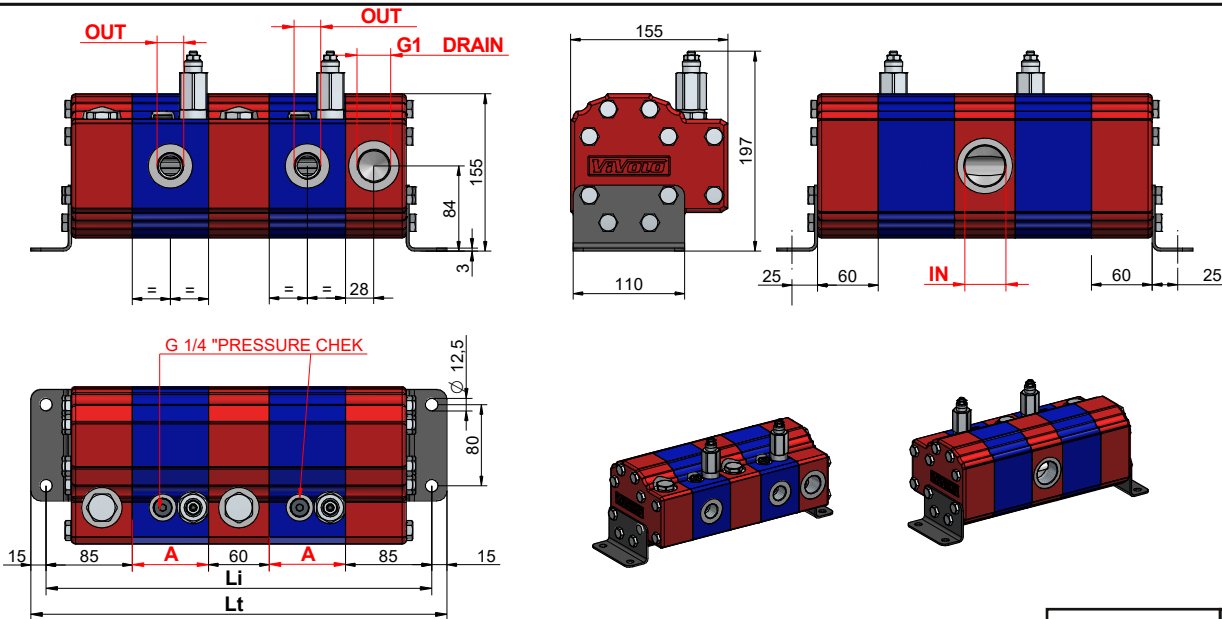

REFERENCES: XV301

### Table: 2

Li = Distance between fixing hole centres (single displacement flow divider)

Cm <sup>3</sup> /rev	A	IN	OUT	Number of elements														
				2	3	4	5	6	7	8	9	10	11	12	13	14	15	16
15	66	1" BSP	1/2 BSP	362	488	614	740	866	992	1118	1244	1370	1496	1622	1748	1874	2000	2126
18	68	1" BSP	1/2 BSP	366	494	622	750	878	1006	1134	1262	1390	1518	1646	1774	1902	2030	2158
21	71	1" BSP	1/2 BSP	372	503	634	765	896	1027	1158	1289	1420	1551	1682	1813	1944	2075	2206
27	75	1" BSP	3/4 BSP	380	515	650	785	920	1055	1190	1325	1460	1595	1730	1865	2000	2135	2270
32	80	1" BSP	3/4 BSP	390	530	670	810	950	1090	1230	1370	1510	1650	1790	1930	2070	2210	2350
38	85	1" BSP	3/4 BSP	400	545	690	835	980	1125	1270	1415	1560	1705	1850	1995	2140	2285	2430
43	89	1" BSP	1" BSP	408	557	706	855	1004	1153	1302	1451	1600	1749	1898	2047	2196	2345	2494
47	92	1-1/4 BSP	1" BSP	414	566	718	870	1022	1174	1326	1478	1630	1782	1934	2086	2238	2390	2542
51	95	1-1/4 BSP	1" BSP	420	575	730	885	1040	1195	1350	1505	1660	1815	1970	2125	2280	2435	2590
54	98	1-1/4 BSP	1" BSP	426	584	742	900	1058	1216	1374	1532	1690	1848	2006	2164	2322	2480	2638
61	103	1-1/4 BSP	1" BSP	436	599	762	925	1088	1251	1414	1577	1740	1903	2066	2229	2392	2555	2718
64	106	1-1/4 BSP	1" BSP	442	608	774	940	1106	1272	1438	1604	1770	1936	2102	2268	2434	2600	2766
70	111	1-1/4 BSP	1" BSP	452	623	794	965	1136	1307	1478	1649	1820	1991	2162	2333	2504	2675	2846
74	114	1-1/4 BSP	1" BSP	458	632	806	980	1154	1328	1502	1676	1850	2024	2198	2372	2546	2720	2894
90	124	1-1/4 BSP	1-1/4 BSP	478	662	846	1030	1214	1398	1582	1766	1950	2134	2318	2502	2686	2870	3054

**Table: 3** in this table the number of inlets in function of the number of elements are indicated.

Number of elements	2	3	4	5	6	7	8	9	10	11	12	13	14	15	16
"IN" Number of inlets	1	2	2	3	3	4	4	5	5	6	6	7	7	8	8

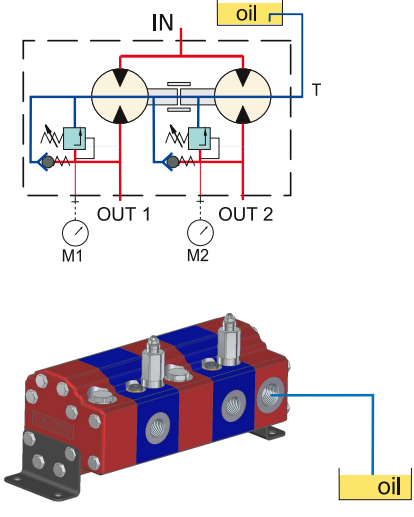
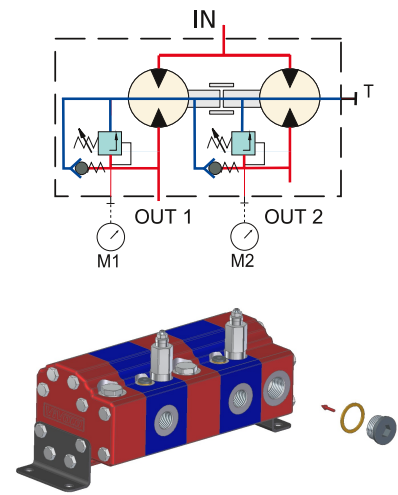
EXTERNAL DRAIN <i>STANDARD SETUP</i>	INTERNAL DRAIN
<p>For the correct functioning of the flow divider, it has to be installed <i>under the oil level</i>. The drain tube has to pick up under the oil level and it has not to aspire air.</p>	<p>To predispose the divider to the internal drain, plug the 1" G drain port ( T )</p> <p><b>Note:</b> with this configuration the function of anticavitation valves is annulled</p>
	

In **table 1** the functioning range of single flow divider elements is indicated.

The higher is the feeding capacity ( q ), the higher is the precision of flow division, but in opposition there are losses of loading and higher noise. Therefore we suggest to feed the elements with capacities equal or a few superior to the ones indicated in the column "**RECOMMENDED**".

It's important remember to verify the capacities even in phase of flow reunion.

The pressures indicated are to be considered as maximum of functioning, the flow divider is able to bear peaks of pressure 20% superior.

**How to calculate the "Li" and "Lt" measures of flow dividers:**

From **table 2** it is possible to obtain the "Li" measure for flow dividers up to 16 elements with equal displacements; for flow dividers with different elements or with more than 16 elements the "Li" and "Lt" measure have to be calculated by the following formula:

$$Li = [(n-1) \times 60] + 170 + (A1 + A2 + A3 + \dots)$$

$$170 = 85 + 85$$

n = Number of elements of flow divider

A1... An = heights of elements of flow divider

$$Lt = Li + 30$$

$$30 = 15 + 15$$

**EXAMPLE:** To obtain the measures **Li** and **Lt** of a flow divider with three elements (n=3), **XV-3V 27 + 38 + 54**

Distance between fixing hole centres

$$Li = [(3-1) \times 60] + 170 + 75 + 85 + 98 = 548 \text{ mm}$$

Total Length

$$Lt = 548 + 30 = 578 \text{ mm}$$

In **table 3** the number of inlets in fuction of the number of elements are indicated.

For flow dividers with many inlets, as they are all communicating it is even possible to use only one of them, by plugging the other ones. We suggest to use at least one 1" BSP inlet every 200 l/min capacity and at least one 1-1/4" BSP inlet every 360 l/min capacity

To obtain errors of division inferior to 3% there must be no difference of pressure between the elements superior to 30 bar. To obtain high precisions the respect of the following parametres is also important:

- Environment temperature: -10°C ÷ +60°C                      Oil temperature: +30°C ÷ +60°C
- Hydraulic oil based on hlp, hv (din 51524) minerals      Oil Viscosity 20 ÷ 40 cSt
- Oil filtering 10 ÷ 25 µ