

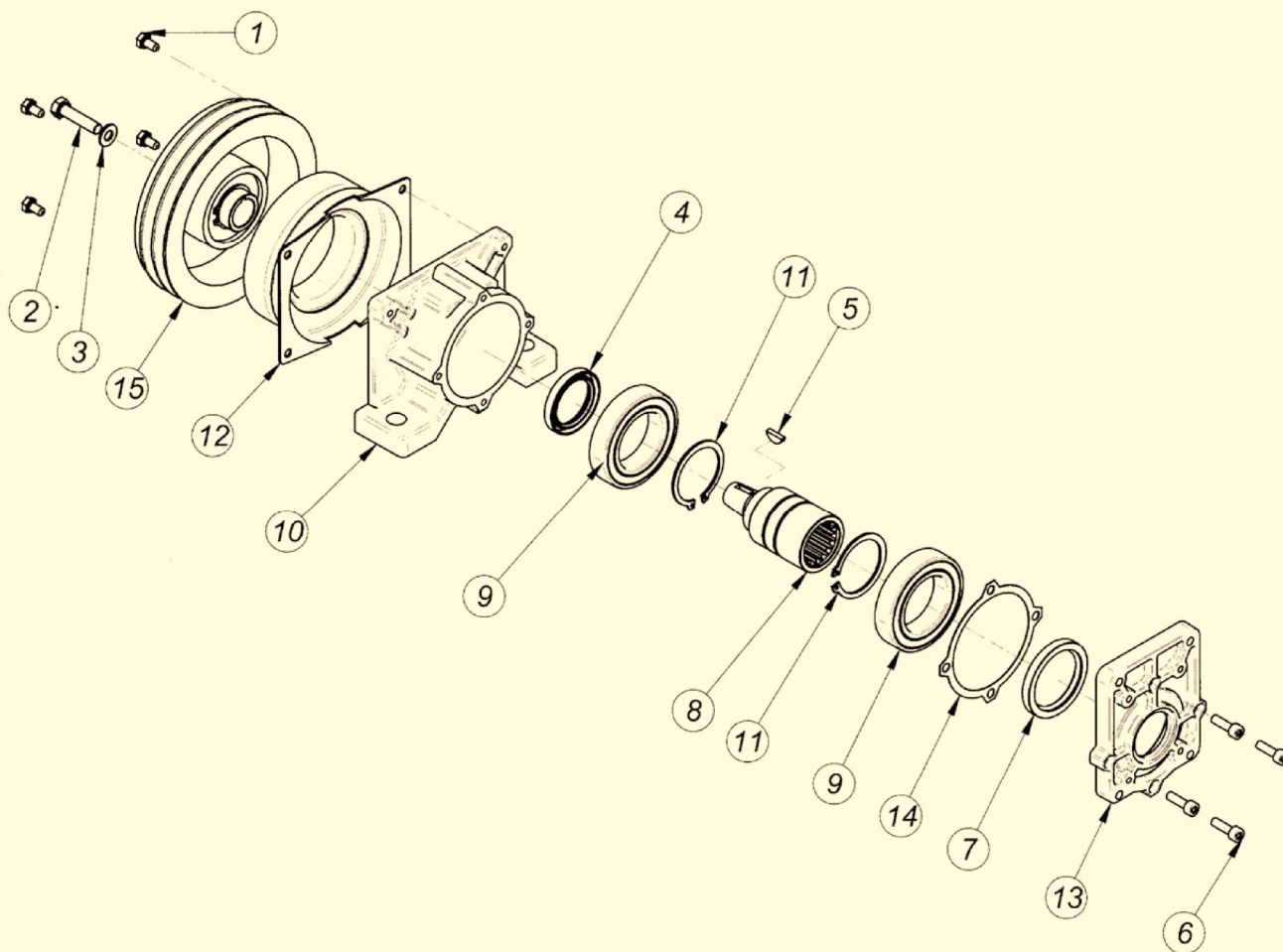

OLEODINAMICA BORELLI
HYDRAULIC COMPONENTS

- TAVOLA RICAMBI INNESTO ELETTRIMAGNETICO 10daNm
- TABLEAU DES PIECES DETACHEES POUR EMBRAYAGE ELECTROMAGNETIQUE 10daNm
- SPARE PARTS TABLE FOR ELECTROMAGNETIC COUPLING 10daNm
- ERSATZTEILLISTE FUR ELEKTROMAGNETISCHE SCHALKUPPLUNGEN 10daNm



Pos.	CODICE	DENOMINAZIONE	DENOMINATION	DESCRIPTION	BEZEICHNUNG	Q. TA'
1	611428	Vite EN 24017 M6x12	Vis EN24017 M6x12	Soket EN 24017 M6x12	Befestigungsschraube EN 24017 M6x12	4
2	610516	Vite EN 24017 M8x35	Vis EN 24017 M8x35	Socket EN 24017 M8x35	Befestigungsschraube EN 24017 M8x35	1
3	RSPAL8	Rosetta per M8	Rondelle D.8	Washer d.8	Rosette durchm 8	1
4	303550	Anello di tenuta 35x50x7	Bague d'etancheite 35x50x7	Sealing ring 35x50x7	Dichtring 35x50x7	1
5	700465	Linguetta UNI 6606 4x6.5	Languette UNI 6606 4x6.5	Woodruff key UNI 6606 4x6.5	Halbrundkeil UNI 6606 4x6.5	1
6	610620	Vite T.C.E.I M6x20	Vis T.C.H.C. M6x20	Socket capscrew M6x20	Befestigungsschraube UNI 5931 M6x20	4
7	304560	Anello di tenuta 45x60x7	Bague d'etancheite 45x60x7	Sealing ring 45x60x7	Dichtring 45x60x7	1
8	A30901	Albero	Arbre	Shaft	Welle	1
9	506009/2Z	Cuscinetto 6009 2rs	Palier SKF 6009 2RS	Bearing SKF 6009 2RS	Kugellager SKF 6009-2RS	2
10	30009.1	Scatola	Carcasse	Housing	Gehäuse	1
11	904500	Anello elastico d.45	Circlip d.45	Snap ring d.45	Seegerring d.45	2
12	401210/153 402410/153	Bobina	Bobine	Coil	Zundspule	1
13	30900.1	Flangia per pompe Gr 1 - 2	Flasque puor pompes Gr 1 - 2	Flange for pumps Gr 1 - 2	Flansch fur pumpe Gr 1- 2	1
14	30009.1.1	Guarnizione	Joint	Gasket	Dichtung	1
15	4010/153P	Elettrofrizione	Electro-embayage	Electric clutch	Elektroschaltkpllung	1



- **INNESTO ELETTROMAGNETICO 10daNm**
- **EMBRAYAGE ELECTROMAGNETIQUE 10daNm**
- **ELECTROMAGNETIC COUPLING 10daNm**
- **ELEKTROMAGNETISCHE SCHALKUPPLUNGEN 10daNm**

SERIE: 30901 12 Volt

SERIE: 30903 24 Volt

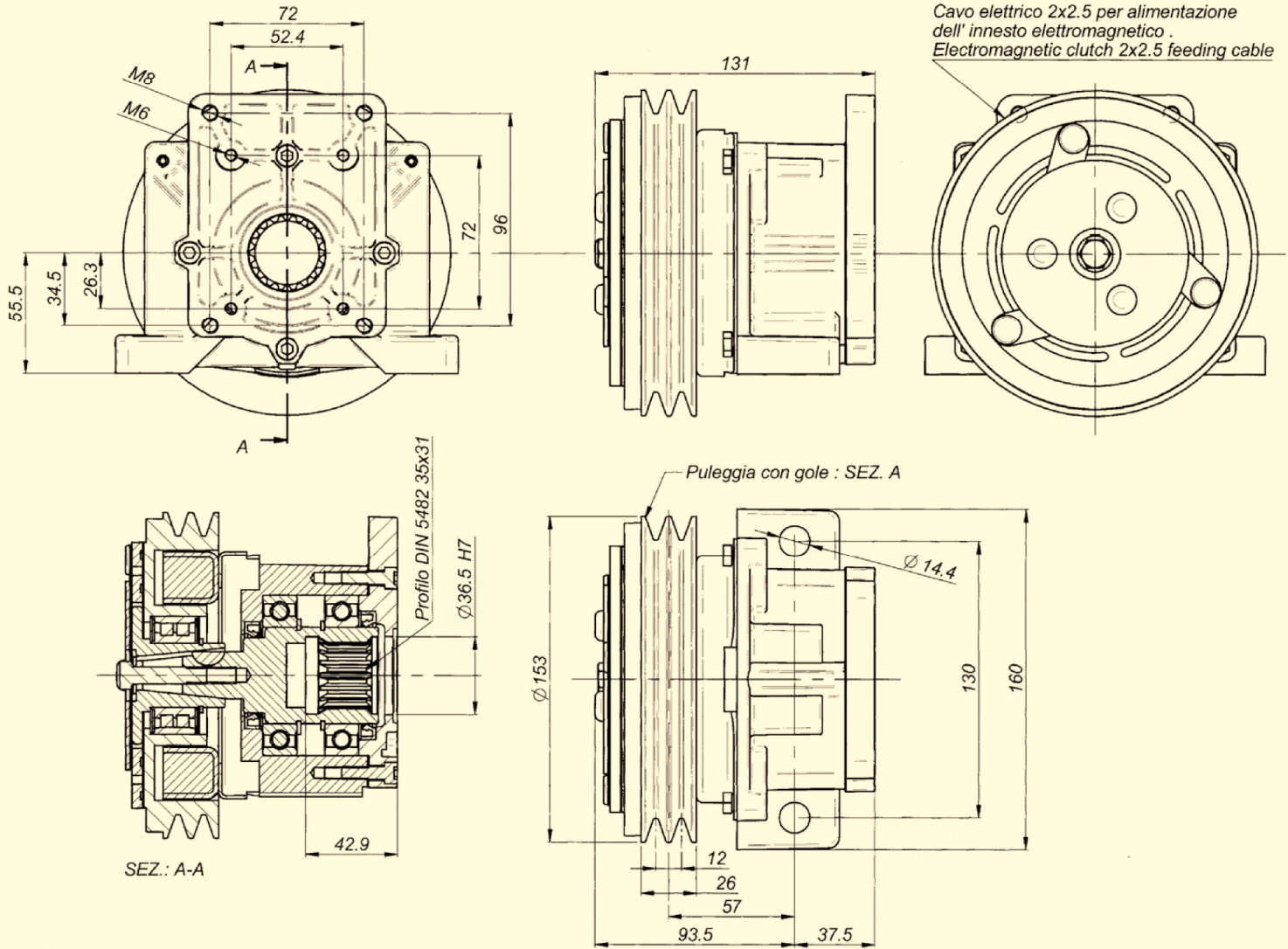

Nominal torque	7,8 daNm		Connection time	25 m/sec		
Static torque	12,5 daNm		Disconnection time	40 m/sec		
Dynamic torque	8,5 daNm	at 500 rpm	Minimum time between two connection	20 sec		
	7,0 daNm	at 1000 rpm				
	4,2 daNm	at 1500 rpm				
	3,5 daNm	at 2000 rpm	Max speed	5000 rpm		
	2,7 daNm	at 2500 rpm	Weight	5,5 Kg		
2,5 daNm	at 3000 rpm					
Electric absorption	Resistance (Ω)		Current (A)		Power (W)	
	20° C	120° C	20° C	120° C	20° C	120° C
12 V DC	4,00	5,60	3,33	2,00	40,00	24,00
24 V DC	20,00	28,00	1,26	0,77	30,30	18,18

All technical data are at 20°C / at 120 °C the performance are less 20%
All electromagneteic clutches are reversible.



- FLANGE PER INNESTI ELETTROMAGNETICI 10 daNm
- BRIDE POUR EMBRAYAGES ELECTROMAGNETIQUE 10 daNm
- FLANGES FOR ELECTROMAGNETIC COUPLING 10 daNm
- FLANSCHEN FÜR ELEKTROMAGNETISCHE SCHALTKUPPLUNGEN 10 daNm

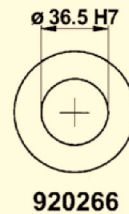
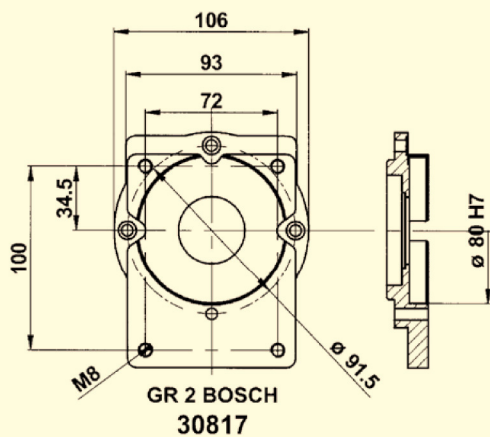
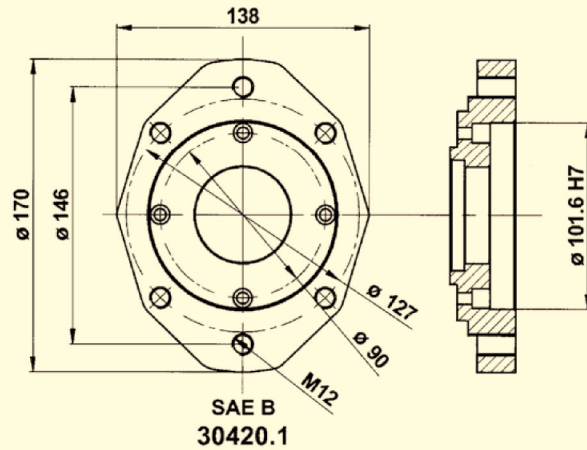
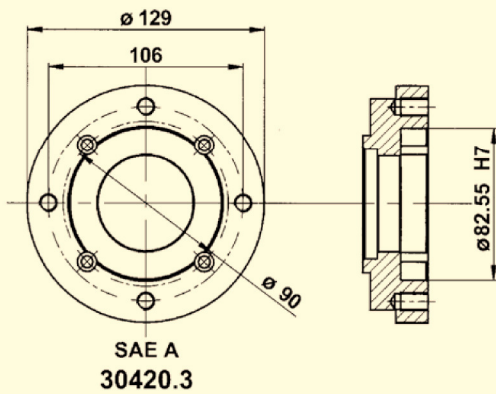
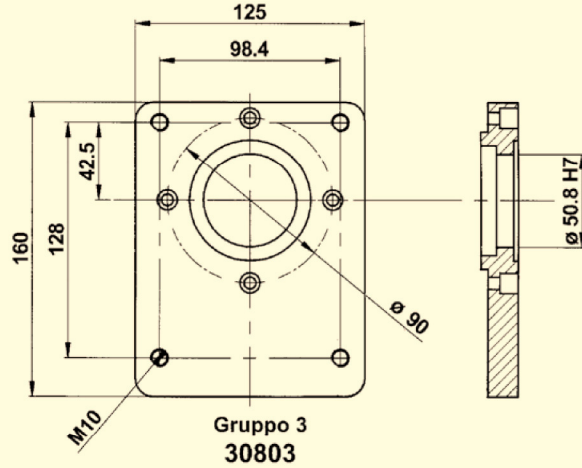
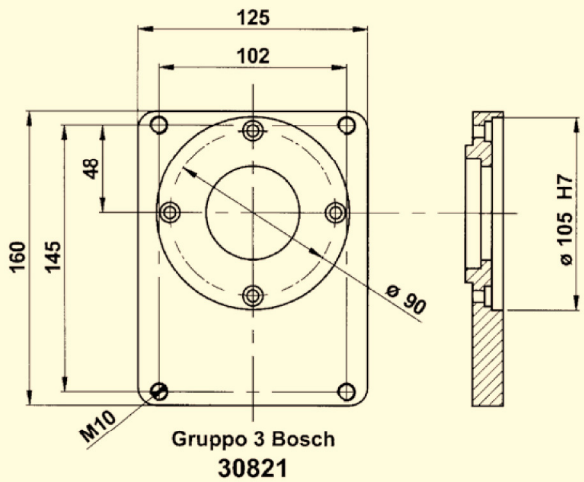

CODICE, CODE, CODE No., CODENUMMER

Electric absorption	FLANGIA: TIPO, BRIDE: TYPE, FLANGE: TYPE, FLANSCHTYPE				
	Gr.2 BOSCH	Gr.3	Gr. 3 BOSCH	SAE A	SAE B
12 Volt	30917	30909	30925	30901/SA	30901/SB
24 Volt	30919	30911	30927	30903/SA	30903/SB