

# unidirectional pump - series XV

# XV-3P

STANDARD EUROPEAN PUMP  
ø50.8 FLANGE - TAPER SHAFT

**X 3 P 78 02 A B B A**

Series	X	series XV
Group	3	group 3
Category	P	unidirectional pump
Displacement	78	38
Flange	02	ø50.8 right rotation
Shaft	A	CO001 - Tapered 1:8 - ø22 - key thk.4
Body	IN	inlet - ø51 ø27 M10
	OUT	outlet - ø51 ø27 M10
Cover	A	standard

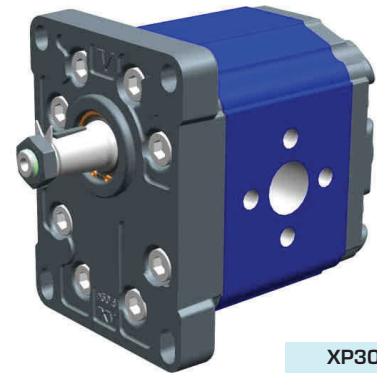

XP301

Technical data table

TYPE	Displacement cm3/rev	Max. Pressure		CODE																	
		P1 bar	P3 bar	Left rotation			Right rotation														
XV-3P/15	14,89	300	320	X	3	P	66	01	A	A	A	A	X	3	P	66	02	A	A	A	A
XV-3P/18	17,37	300	320	X	3	P	68	01	A	A	A	A	X	3	P	68	02	A	A	A	A
XV-3P/21	21,10	280	300	X	3	P	70	01	A	A	A	A	X	3	P	70	02	A	A	A	A
XV-3P/27	26,97	250	270	X	3	P	72	01	A	A	A	A	X	3	P	72	02	A	A	A	A
XV-3P/32	32,27	250	270	X	3	P	74	01	A	B	B	A	X	3	P	74	02	A	B	B	A
XV-3P/38	38,47	250	270	X	3	P	78	01	A	B	B	A	X	3	P	78	02	A	B	B	A
XV-3P/43	43,44	250	270	X	3	P	79	01	A	B	B	A	X	3	P	79	02	A	B	B	A
XV-3P/47	47,16	230	250	X	3	P	80	01	A	B	B	A	X	3	P	80	02	A	B	B	A
XV-3P/51	50,88	230	250	X	3	P	81	01	A	B	B	A	X	3	P	81	02	A	B	B	A
XV-3P/54	54,60	230	250	X	3	P	82	01	A	B	B	A	X	3	P	82	02	A	B	B	A
XV-3P/61	60,81	230	250	X	3	P	83	01	A	C	C	A	X	3	P	83	02	A	C	C	A
XV-3P/64	64,53	210	230	X	3	P	85	01	A	C	C	A	X	3	P	85	02	A	C	C	A
XV-3P/70	70,74	200	220	X	3	P	86	01	A	C	C	A	X	3	P	86	02	A	C	C	A
XV-3P/74	74,46	180	200	X	3	P	87	01	A	C	C	A	X	3	P	87	02	A	C	C	A
XV-3P/90	86,87	150	170	X	3	P	89	01	A	C	C	A	X	3	P	89	02	A	C	C	A

P1) Max. working pressure - P3) Max. peak pressure

For heavy-duty applications, it is recommended to check the admissible torque of the shaft

Dimensions table

TYPE	Weight kg	A	B	D	E	F	D	E	F
		mm	mm	IN			OUT		
XV-3P/15	7,010	124,0	61,0	ø20	40	M8	ø20	40	M8
XV-3P/18	7,070	126,0	62,0	ø20	40	M8	ø20	40	M8
XV-3P/21	7,150	129,0	63,5	ø20	40	M8	ø20	40	M8
XV-3P/27	7,250	133,0	65,5	ø20	40	M8	ø20	40	M8
XV-3P/32	7,390	138,0	68,0	ø27	51	M10	ø27	51	M10
XV-3P/38	7,520	143,0	70,5	ø27	51	M10	ø27	51	M10
XV-3P/43	7,630	147,0	72,5	ø27	51	M10	ø27	51	M10
XV-3P/47	7,710	150,0	74,0	ø27	51	M10	ø27	51	M10
XV-3P/51	7,790	153,0	75,5	ø27	51	M10	ø27	51	M10
XV-3P/54	7,870	156,0	77,0	ø27	51	M10	ø27	51	M10
XV-3P/61	8,010	161,0	79,5	ø36	62	M10	ø36	62	M10
XV-3P/64	8,090	164,0	81,0	ø36	62	M10	ø36	62	M10
XV-3P/70	8,220	169,0	83,5	ø36	62	M10	ø36	62	M10
XV-3P/74	8,300	172,0	85,0	ø36	62	M10	ø36	62	M10
XV-3P/90	8,570	182,0	90,0	ø36	62	M10	ø36	62	M10

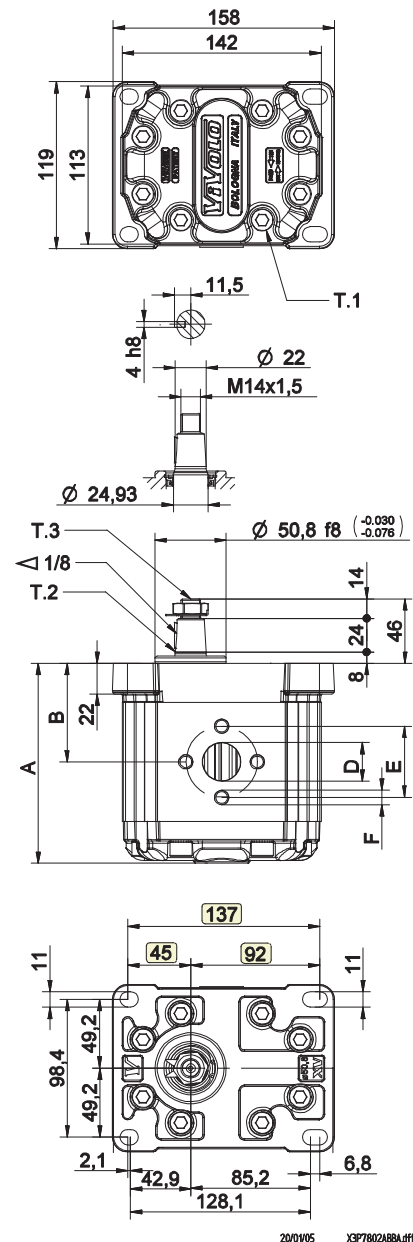

T.1 = 60+65 [Nm] - screw tightening torque M10

T.3 = 75 [Nm] - torque wrench setting 22

T.2 = 482 [Nm] - admissible shaft torque (N.B. When choosing a shaft, always check the admissible torque).

# Table of variations

XV-3P

## ø50.8 FLANGE

ø50.8 FLANGE		Shaft		Cover	
Left rotation	Right rotation			Left rotation	Right rotation
		CO001 - Tapered T.2 = 482 [Nm] 	CI001 - Parallel T.2 = 181 [Nm] 		
01	02	A	B	A	A
		SCF03 - Splined T.2 = 223 [Nm] 	CI004 - Parallel T.2 = 180 [Nm] 		
		C	H	B	B
		SCF04 - Splined T.2 = 264 [Nm] 			
		I		C	C
				D	D

Displacement	
TYPE	CODE
XV-3P/15	66
XV-3P/18	68
XV-3P/21	70
XV-3P/27	72
XV-3P/32	74
XV-3P/38	78
XV-3P/43	79
XV-3P/47	80
XV-3P/51	81
XV-3P/54	82
XV-3P/61	83
XV-3P/64	85
XV-3P/70	86
XV-3P/74	87
XV-3P/90	89

Standard bodies				
Displacement cm3/rev	Standard threads			
	14	A - A	D - D	H - H
17	A - A	D - D	H - H	
21	A - A	D - D	H - H	
26	A - A	E - E	H - H	
32	B - B	E - E	H - H	
38	B - B	E - E	H - H	
43	B - B	E - E	H - H	
47	B - B	E - E	H - H	
51	B - B	E - E	H - H	
54	B - B	E - E	H - H	
61	C - C	F - F		
64	C - C	F - F		
70	C - C	F - F		
74	C - C	F - F		
90	C - C	F - F		

Table showing standard flange and thread combinations available in stock

Body (threads/flanges)													
	A		B		C		D		E		F		G
	H		I		L		M		N		O		P
Closed Body	Z												

# unidirectional pump - series XV

# XV-3P

STANDARD EUROPEAN PUMP  
ø50.8 FLANGE - TAPER SHAFT

**X 3 P 78 02 A E E A**

Series	X	series XV
Group	3	group 3
Category	P	unidirectional pump
Displacement	78	38
Flange	02	ø50.8 right rotation
Shaft	A	CO001 - Tapered 1:8 - ø22 - key thk.4
Body	IN	E inlet - 1" BSP
	OUT	E outlet - 1" BSP
Cover	A	standard

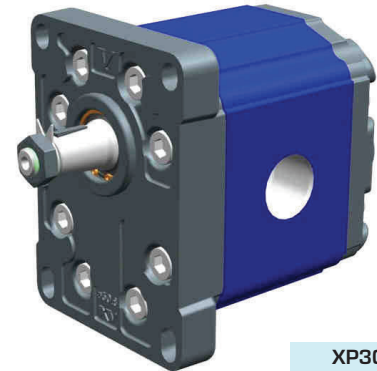

XP302

Technical data table

TYPE	Displacement cm3/rev	Max. Pressure		CODE			
		P1 bar	P3 bar	Left rotation		Right rotation	
XV-3P/15	14,89	300	320	X 3 P 66 01 A D D A	X 3 P 66 02 A D D A		
XV-3P/18	17,37	300	320	X 3 P 68 01 A D D A	X 3 P 68 02 A D D A		
XV-3P/21	21,10	280	300	X 3 P 70 01 A D D A	X 3 P 70 02 A D D A		
XV-3P/27	26,97	250	270	X 3 P 72 01 A E E A	X 3 P 72 02 A E E A		
XV-3P/32	32,27	250	270	X 3 P 74 01 A E E A	X 3 P 74 02 A E E A		
XV-3P/38	38,47	250	270	X 3 P 78 01 A E E A	X 3 P 78 02 A E E A		
XV-3P/43	43,44	250	270	X 3 P 79 01 A E E A	X 3 P 79 02 A E E A		
XV-3P/47	47,16	230	250	X 3 P 80 01 A E E A	X 3 P 80 02 A E E A		
XV-3P/51	50,88	230	250	X 3 P 81 01 A E E A	X 3 P 81 02 A E E A		
XV-3P/54	54,60	230	250	X 3 P 82 01 A E E A	X 3 P 82 02 A E E A		
XV-3P/61	60,81	230	250	X 3 P 83 01 A F F A	X 3 P 83 02 A F F A		
XV-3P/64	64,53	210	230	X 3 P 85 01 A F F A	X 3 P 85 02 A F F A		
XV-3P/70	70,74	200	220	X 3 P 86 01 A F F A	X 3 P 86 02 A F F A		
XV-3P/74	74,46	180	200	X 3 P 87 01 A F F A	X 3 P 87 02 A F F A		
XV-3P/90	86,87	150	170	X 3 P 89 01 A F F A	X 3 P 89 02 A F F A		

P1) Max. working pressure - P3) Max. peak pressure

For heavy-duty applications, it is recommended to check the admissible torque of the shaft

Dimensions table

TYPE	Weight	A	B	D	D
	kg	mm	mm	IN	OUT
XV-3P/15	7,010	124,0	61,0	3/4" BSPP	3/4" BSPP
XV-3P/18	7,070	126,0	62,0	3/4" BSPP	3/4" BSPP
XV-3P/21	7,150	129,0	63,5	3/4" BSPP	3/4" BSPP
XV-3P/27	7,250	133,0	65,5	1" BSPP	1" BSPP
XV-3P/32	7,390	138,0	68,0	1" BSPP	1" BSPP
XV-3P/38	7,520	143,0	70,5	1" BSPP	1" BSPP
XV-3P/43	7,630	147,0	72,5	1" BSPP	1" BSPP
XV-3P/47	7,710	150,0	74,0	1" BSPP	1" BSPP
XV-3P/51	7,790	153,0	75,5	1" BSPP	1" BSPP
XV-3P/54	7,870	156,0	77,0	1" BSPP	1" BSPP
XV-3P/61	8,010	161,0	79,5	1" 1/4 BSPP	1" 1/4 BSPP
XV-3P/64	8,090	164,0	81,0	1" 1/4 BSPP	1" 1/4 BSPP
XV-3P/70	8,220	169,0	83,5	1" 1/4 BSPP	1" 1/4 BSPP
XV-3P/74	8,300	172,0	85,0	1" 1/4 BSPP	1" 1/4 BSPP
XV-3P/90	8,570	182,0	90,0	1" 1/4 BSPP	1" 1/4 BSPP

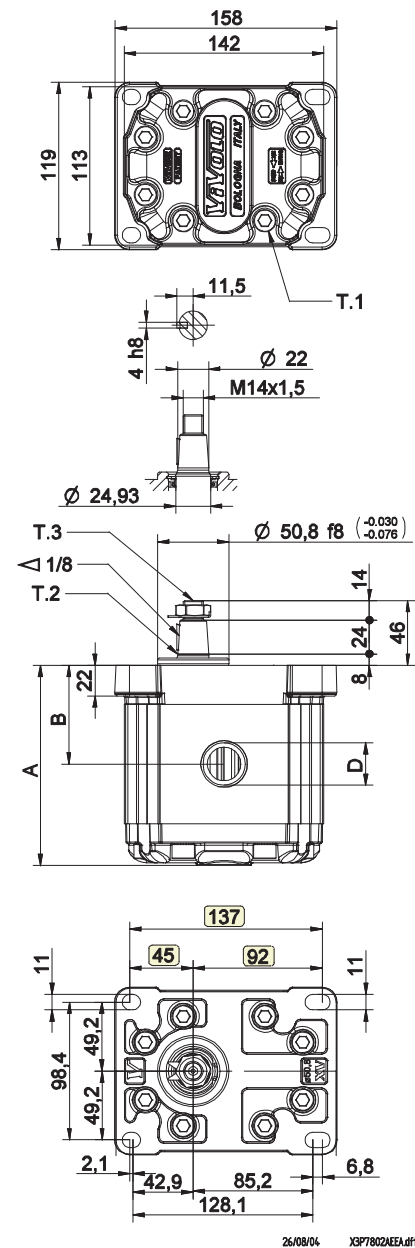

26/08/04 XP37802AEEA.dft

T.1 = 60+65 [Nm] - screw tightening torque M10

T.3 = 75 [Nm] - torque wrench setting 22

T.2 = 482 [Nm] - admissible shaft torque (N.B. When choosing a shaft, always check the admissible torque).

# Table of variations

XV-3P

## ø50.8 FLANGE

ø50.8 FLANGE		Shaft		Cover	
Left rotation	Right rotation			Left rotation	Right rotation
		CO001 - Tapered T.2 = 482 [Nm]	CI001 - Parallel T.2 = 181 [Nm]		
01	02	A	B	A	A
		SCF03 - Splined T.2 = 223 [Nm]	CI004 - Parallel T.2 = 180 [Nm]		
		C	H	B	B
		SCF04 - Splined T.2 = 264 [Nm]			
		I		C	C
				D	D

Displacement	
TYPE	CODE
XV-3P/15	66
XV-3P/18	68
XV-3P/21	70
XV-3P/27	72
XV-3P/32	74
XV-3P/38	78
XV-3P/43	79
XV-3P/47	80
XV-3P/51	81
XV-3P/54	82
XV-3P/61	83
XV-3P/64	85
XV-3P/70	86
XV-3P/74	87
XV-3P/90	89

Standard bodies				
Displacement cm3/rev	Standard threads			
14	A - A	D - D	H - H	
17	A - A	D - D	H - H	
21	A - A	D - D	H - H	
26	A - A	E - E	H - H	
32	B - B	E - E	H - H	
38	B - B	E - E	H - H	
43	B - B	E - E	H - H	
47	B - B	E - E	H - H	
51	B - B	E - E	H - H	
54	B - B	E - E	H - H	
61	C - C	F - F		
64	C - C	F - F		
70	C - C	F - F		
74	C - C	F - F		
90	C - C	F - F		

Table showing standard flange and thread combinations available in stock

Body (threads/flanges)													
	A		B		C		D		E		F		G
	H		I		L		M		N		O		P
Closed Body	Z												