

unidirectional pump - series XV

XV-2P

"SAE A" TYPE PUMP
 ø82.5 FLANGE - SPLINED SHAFT

X 2 P 51 52 I S R A

Series	X	series XV
Group	2	group 2
Category	P	unidirectional pump
Displacement	51	17
Flange	52	Ø82.5 SAE A right rotation (with OR)
Shaft	I	SCF04 - Splined ø15.456 z=9, H=22.5 - SAE J498 9T 16/32DP
Body	IN	S inlet - Ø40 a 45° Ø20 M6
	OUT	R outlet - Ø35 a 45° Ø15 M6
Cover	A	standard

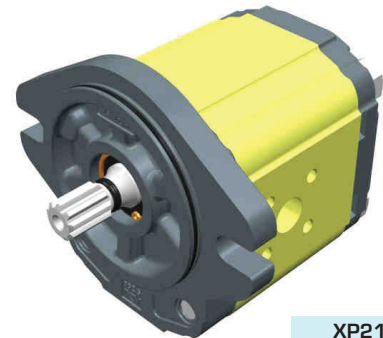

XP219

Technical data table						
TYPE	Displacement cm3/rev	Max. Pressure		CODE		
		P1 bar	P3 bar	Left rotation		Right rotation
XV-2P/04	4,20	260	300	X 2 P 41 51 I S R A	X 2 P 41 52 I S R A	X 2 P 41 52 I S R A
XV-2P/06	6,00	260	300	X 2 P 43 51 I S R A	X 2 P 43 52 I S R A	X 2 P 43 52 I S R A
XV-2P/09	8,40	260	300	X 2 P 45 51 I S R A	X 2 P 45 52 I S R A	X 2 P 45 52 I S R A
XV-2P/11	10,80	260	300	X 2 P 47 51 I S R A	X 2 P 47 52 I S R A	X 2 P 47 52 I S R A
XV-2P/14	14,40	250	290	X 2 P 49 51 I S R A	X 2 P 49 52 I S R A	X 2 P 49 52 I S R A
XV-2P/17	16,80	230	270	X 2 P 51 51 I S R A	X 2 P 51 52 I S R A	X 2 P 51 52 I S R A
XV-2P/19	19,20	210	250	X 2 P 53 51 I S R A	X 2 P 53 52 I S R A	X 2 P 53 52 I S R A
XV-2P/22	22,80	200	240	X 2 P 55 51 I S R A	X 2 P 55 52 I S R A	X 2 P 55 52 I S R A
XV-2P/26	26,20	170	210	X 2 P 57 51 I S R A	X 2 P 57 52 I S R A	X 2 P 57 52 I S R A
XV-2P/30	30,00	160	200	X 2 P 59 51 I S S A	X 2 P 59 52 I S S A	X 2 P 59 52 I S S A
XV-2P/34	34,20	150	190	X 2 P 61 51 I S S A	X 2 P 61 52 I S S A	X 2 P 61 52 I S S A
XV-2P/40	39,60	140	180	X 2 P 63 51 I S S A	X 2 P 63 52 I S S A	X 2 P 63 52 I S S A

P1) Max. working pressure - P3) Max. peak pressure

For heavy-duty applications, it is recommended to check the admissible torque of the shaft

Dimensions table										
TYPE	Weight kg	A	B	C	D	E	F	D	E	F
		mm	mm	mm	IN			OUT		
XV-2P/04	2,280	88,0	39,4	78,0	ø20	40	M6x1	ø15	35	M6x1
XV-2P/06	2,380	91,0	39,4	81,0	ø20	40	M6x2	ø15	35	M6x1
XV-2P/09	2,480	95,0	41,4	85,0	ø20	40	M6x3	ø15	35	M6x1
XV-2P/11	2,580	99,0	45,8	89,0	ø20	40	M6x4	ø15	35	M6x1
XV-2P/14	2,780	105,0	45,8	95,0	ø20	40	M6x5	ø15	35	M6x1
XV-2P/17	2,880	109,0	45,8	99,0	ø20	40	M6x6	ø15	35	M6x1
XV-2P/19	2,980	113,0	45,8	103,0	ø20	40	M6x7	ø15	35	M6x1
XV-2P/22	3,130	119,0	53,3	109,0	ø20	40	M6x8	ø15	35	M6x1
XV-2P/26	3,230	123,0	53,3	113,0	ø20	40	M6x9	ø15	35	M6x1
XV-2P/30	3,480	131,0	61,5	121,0	ø20	40	M6x10	ø20	40	M6x1
XV-2P/34	3,680	138,0	61,5	128,0	ø20	40	M6x11	ø20	40	M6x1
XV-2P/40	3,880	147,0	61,5	137,0	ø20	40	M6x12	ø20	40	M6x1

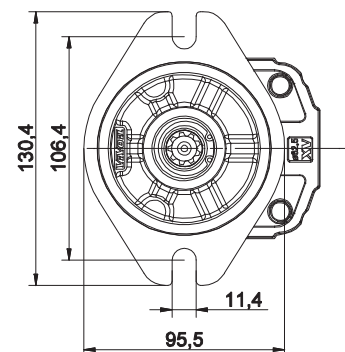
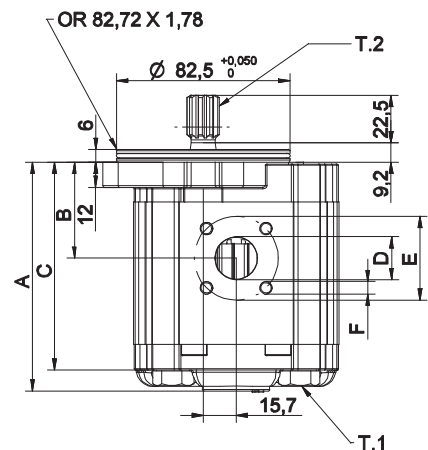
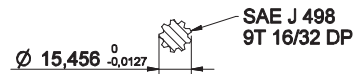
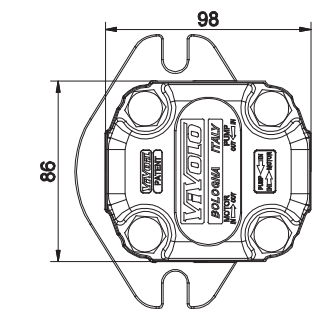

26/06/04 XV2P52SRAl1ff

T.1 = 54+58.9 [Nm] - screw tightening torque M10

T.2 = 67.1 [Nm] - admissible shaft torque (N.B. When choosing a shaft, always check the admissible torque).

Table of variations

XV-2P

ø82.5 FLANGE "SAE A"

ø82.5 FLANGE "SAE A"		Shaft		Cover	
Left rotation	Right rotation			Left rotation	Right rotation
		CI001 - Parallel T.2 = 44.1 [Nm]	CI002 - Parallel T.2 = 67.5 [Nm]		
		CO001 - Tapered T.2 = 233.2 [Nm]	CO002 - Tapered T.2 = 233.2 [Nm]		
Without OR	Without OR	SCF04 - Splined T.2 = 67.1 [Nm]			

Displacement		Standard bodies						
TYPE	CODE	Displacement cm ³ /rev	Standard threads					
XV-2P/04	41	04	O - O	S - R	B - B	L - M	Z - Z	
XV-2P/06	43	06	O - O	S - R	B - B	L - M	Z - Z	
XV-2P/09	45	09	O - O	S - R	B - B	L - M	Z - Z	
XV-2P/11	47	11	O - O	S - R	B - B	L - M	Z - Z	
XV-2P/14	49	14	P - O	S - R	C - B	L - M	Z - Z	
XV-2P/17	51	17	P - O	S - R	C - B	L - M	Z - Z	
XV-2P/19	53	19	P - O	S - R	C - B	L - M	Z - Z	
XV-2P/22	55	22	P - O	S - R	C - B	L - M	Z - Z	
XV-2P/26	57	26	Q - P	S - R	D - C	L - M	Z - Z	
XV-2P/30	59	30	Q - P	S - S	D - C	L - M	Z - Z	
XV-2P/34	61	34	Q - P	S - S	D - C	L - M	Z - Z	
XV-2P/40	63	40	Q - P	S - S	D - C	L - M	Z - Z	

Table showing standard flange and thread combinations available in stock

Body (threads/flanges)													
	A		B		C		D		E		F		G
	H		I		L		M		N		O		P
	Q		R		S		T		U		V		Z