

unidirectional pump - series XV

XV-2P

STANDARD GERMAN PUMP
ø80 FLANGE - TAPER SHAFT



X 2 P 51 42 F S R A

Series	X	series XV
Group	2	group 2
Category	P	unidirectional pump
Displacement	51	17
Flange	42	Ø80 GERMAN STANDARDIZED right rotation (with OR)
Shaft	F	CO002 - Tapered 1:5 - ø17.4 - M12x1.5 - key thk.3
Body	IN	S inlet - Ø40 a 45° Ø20 M6
	OUT	R outlet - Ø35 a 45° Ø15 M6
Cover	A	standard

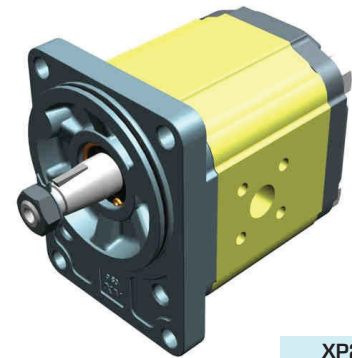

XP217

Technical data table

TYPE	Displacement cm3/rev	Max. Pressure		CODE	
		P1 bar	P3 bar	Left rotation	Right rotation
XV-2P/04	4,20	260	300	X 2 P 41 41 F S R A	X 2 P 41 42 F S R A
XV-2P/06	6,00	260	300	X 2 P 43 41 F S R A	X 2 P 43 42 F S R A
XV-2P/09	8,40	260	300	X 2 P 45 41 F S R A	X 2 P 45 42 F S R A
XV-2P/11	10,80	260	300	X 2 P 47 41 F S R A	X 2 P 47 42 F S R A
XV-2P/14	14,40	250	290	X 2 P 49 41 F S R A	X 2 P 49 42 F S R A
XV-2P/17	16,80	230	270	X 2 P 51 41 F S R A	X 2 P 51 42 F S R A
XV-2P/19	19,20	210	250	X 2 P 53 41 F S R A	X 2 P 53 42 F S R A
XV-2P/22	22,80	200	240	X 2 P 55 41 F S R A	X 2 P 55 42 F S R A
XV-2P/26	26,20	170	210	X 2 P 57 41 F S R A	X 2 P 57 42 F S R A
XV-2P/30	30,00	160	200	X 2 P 59 41 F S S A	X 2 P 59 42 F S S A
XV-2P/34	34,20	150	190	X 2 P 61 41 F S S A	X 2 P 61 42 F S S A
XV-2P/40	39,60	140	180	X 2 P 63 41 F S S A	X 2 P 63 42 F S S A

P1) Max. working pressure - P3) Max. peak pressure

For heavy-duty applications, it is recommended to check the admissible torque of the shaft

Dimensions table

TYPE	Weight kg	A	B	C	D	E	F	D	E	F
		mm	mm	mm	IN			OUT		
XV-2P/04	2,330	89,7	41,1	79,7	ø20	40	M6x1	ø15	35	M6x1
XV-2P/06	2,430	92,7	41,1	82,7	ø20	40	M6x2	ø15	35	M6x1
XV-2P/09	2,530	96,7	43,1	86,7	ø20	40	M6x3	ø15	35	M6x1
XV-2P/11	2,630	100,7	47,5	90,7	ø20	40	M6x4	ø15	35	M6x1
XV-2P/14	2,730	106,7	47,5	96,7	ø20	40	M6x5	ø15	35	M6x1
XV-2P/17	2,830	110,7	47,5	100,7	ø20	40	M6x6	ø15	35	M6x1
XV-2P/19	2,930	114,7	47,5	104,7	ø20	40	M6x7	ø15	35	M6x1
XV-2P/22	3,180	120,7	55,0	110,7	ø20	40	M6x8	ø15	35	M6x1
XV-2P/26	3,280	124,7	55,0	114,7	ø20	40	M6x9	ø15	35	M6x1
XV-2P/30	3,530	132,7	63,2	122,7	ø20	40	M6x10	ø20	40	M6x1
XV-2P/34	3,730	139,7	63,2	129,7	ø20	40	M6x11	ø20	40	M6x1
XV-2P/40	3,930	148,7	63,2	138,7	ø20	40	M6x12	ø20	40	M6x1

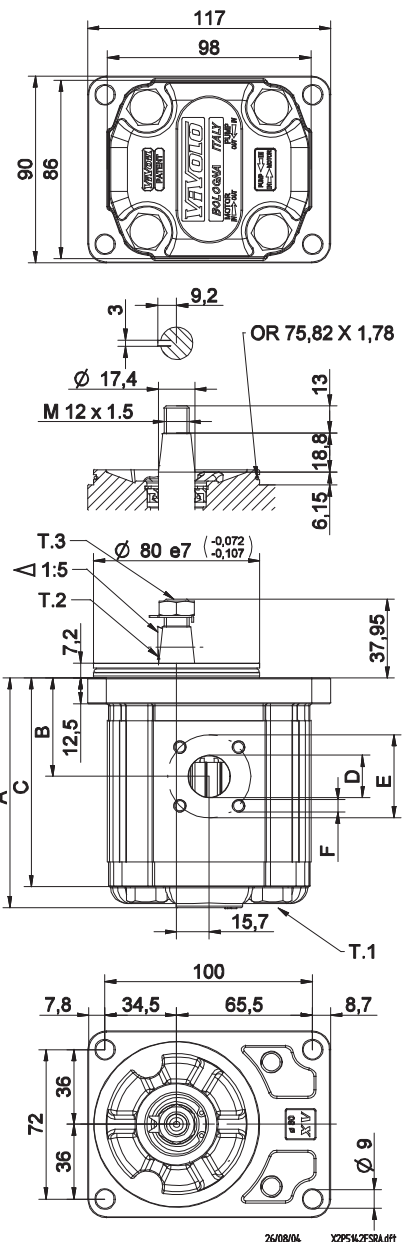

T.1 = 54+58.9 [Nm] - screw tightening torque M10

T.3 = 40 [Nm] - torque wrench setting 19

T.2 = 233.2 [Nm] - admissible shaft torque (N.B. When choosing a shaft, always check the admissible torque).

Table of variations

XV-2P

ø80 FLANGE

ø80 FLANGE		Shaft		Cover	
Left rotation	Right rotation			Left rotation	Right rotation
		CI001 - Parallel T.2 = 44.1 [Nm]	CI002 - Parallel T.2 = 67.5 [Nm]		
41	42	A	B	A	A
		CO001 - Tapered T.2 = 233.2 [Nm]	CO002 - Tapered T.2 = 233.2 [Nm]		
		E	F	B	B
		SCF03 - Splined T.2 = 86.1 [Nm]			
		H		C	C
				D	D
				N	N
				O	O

Displacement		Standard bodies							
TYPE	CODE	Displacement cm ³ /rev	Standard threads						
XV-2P/04	41	04	O - O	S - R	B - B	L - M	Z - Z	Z - Z	
XV-2P/06	43	06	O - O	S - R	B - B	L - M	Z - Z	Z - Z	
XV-2P/09	45	09	O - O	S - R	B - B	L - M	Z - Z	Z - Z	
XV-2P/11	47	11	O - O	S - R	B - B	L - M	Z - Z	Z - Z	
XV-2P/14	49	14	P - O	S - R	C - B	L - M	Z - Z	Z - Z	
XV-2P/17	51	17	P - O	S - R	C - B	L - M	Z - Z	Z - Z	
XV-2P/19	53	19	P - O	S - R	C - B	L - M	Z - Z	Z - Z	
XV-2P/22	55	22	P - O	S - R	C - B	L - M	Z - Z	Z - Z	
XV-2P/26	57	26	Q - P	S - R	D - C	L - M	Z - Z	Z - Z	
XV-2P/30	59	30	Q - P	S - S	D - C	L - M	Z - Z	Z - Z	
XV-2P/34	61	34	Q - P	S - S	D - C	L - M	Z - Z	Z - Z	
XV-2P/40	63	40	Q - P	S - S	D - C	L - M	Z - Z	Z - Z	

Table showing standard flange and thread combinations available in stock

Body (threads/flanges)													
	A		B		C		D		E		F		G
	H		I		L		M		N		O		P
	Q		R		S		T		U		V		Z