

# PV Series Axial Piston Pump

**NEW -PV PLUS**



**\*Feature:**

- Large servo piston with strong bias spring achieves fast response; e.g. for PV46 upstroke < 70 ms downstroke < 40 ms note: follow installation instructions.
- Reduced pressure peaks due to active decompression of system at downstroke.
- Also at low system pressure reliable compensator operation. lowest compensating pressure <10 bar
- Nine piston and new precompression technology (precompression filter volume) result in unbeaten low outlet flow pulsation.
- Rigid and FEM-optimized body design for lowest noise level.
- Complete compensator program.
- Thru drive for 100% nominal torque.
- Pump combinations (multiple pumps) of same size and model and mounting interface for basically all metric or SAE mounting interfaces.

**Ordering code (Preferred Program)**

**PV 0 1 6 A 3 R M 1 A**

Axial piston pump variable displacement high pressure version  
 Size and Displacement  
 Compensator  
 Rotation  
 Mounting code  
 Threads code  
 Voltage  
 Seals  
 Design number Not require for order

Code	Displacement
16	16 cm <sup>3</sup> /rev
20	20 cm <sup>3</sup> /rev
23	23 cm <sup>3</sup> /rev
32	32 cm <sup>3</sup> /rev
40	40 cm <sup>3</sup> /rev
46	46 cm <sup>3</sup> /rev
63	63 cm <sup>3</sup> /rev
71	71 cm <sup>3</sup> /rev
80	80 cm <sup>3</sup> /rev
92	92 cm <sup>3</sup> /rev
140	140 cm <sup>3</sup> /rev
180	180 cm <sup>3</sup> /rev

Code	Rotation
R	clockwise
L	counterclockwise

Code	Port	Threads
*1	BSP(G)	Metric
*2	PT(RC)	Pipe tape
3	UNF	UNC
4	NPT	Inch
7	ISO6149	UNC

Code	Shaft
*M	Metric Cylindric, Key
K	Metric Splined, DIN 5480
N	Inch Cylindric, Key
D	Inch Splined, SAE

Code	Material
*None	NBR
V	FPM
E	Ethylen-propylen

Code	Thru drive option
A	AC 100V (50-60Hz)
B	AC 110V (60Hz)
C	AC 200V (50-60Hz)
D	AC 220V (60Hz)
E	DC 12V
F	DC 24V

Code	Compensator option	horse power
A	Standard pressure compensator	3 KW
*A 2	10-140 bar, spindle+lock nut	4 KW
*A 3	30-250bar, spindle+lock nut	5.5 KW
*A 4	70-350 bar, spindle+lock nut	7.5 KW
G T	Remote pressure compensator	11 KW
G M	Remote pressure interface NG6	13 KW
H L	Load-sensing compensator	18.5 KW
H M	Load-sensing interface NG6	22 KW
H J	2-valve load-sensing interface NG6	30 KW
H Q	Electrohydraulic compensator	37 KW
H K	Loading Sensing & Proportional Flow Control	45 KW
D R	Solenoid controlled with unloading	55 KW
E F	Solenoid two pressure control	75 KW
E D	2-Pressure with solenoid unloading	90 KW
P G	Horse power compensator, pilot flow internal	110 KW
P M	Horse power pressure pilot valve included	132 KW
P H	Horse power compensator+load-sensing pilot vavel	

Code	Thru drive option
*A	Single pump
B	Prepared for thru drive
C	SAE AA, φ 50.8mm
D	SAE A, φ 82.55mm
E	SAE B, φ 101.6mm
F	SAE C, φ 127mm
G	SAE D, φ 152.4mm
H	SAE E, φ 165.1mm
I	Metric, φ 63
J	Metric, φ 80
K	Metric, φ 100
L	Metric, φ 125
M	Metric, φ 160
N	Metric, φ 200

\* IS STANDARD

**Characteristic Data for Single Pumps**

model	max. displacement in cm <sup>3</sup> /rev	nominal flow in l/min at 1500 rpm	nominal input power at 1500 rpm and 350 bar	max. speed <sup>1)</sup> in rpm	weight kg
PV16	16	24	15.5		
PV20	20	30	19.5	2750	19
PV23	23	34.5	22.5		
PV32	32	48	31		
PV40	40	60	39	2400	30
PV46	46	69	45		
PV63	63	94.5	61.5	2100	
PV71	71	106.5	69.3	2100	
PV80	80	120	78	2000	60
PV92	92	138	89.5	1900	
PV140	140	210	136	1800	90
PV180	180	270	175	1800	90

1)The max. self priming speed is valid for an inlet pressure of 1 bar (absolute) and a viscosity of 30 mm<sup>2</sup>/s

# PV Series Axial Piston Pump

## NEW PV PLUS

### PV Series Main Dimensions

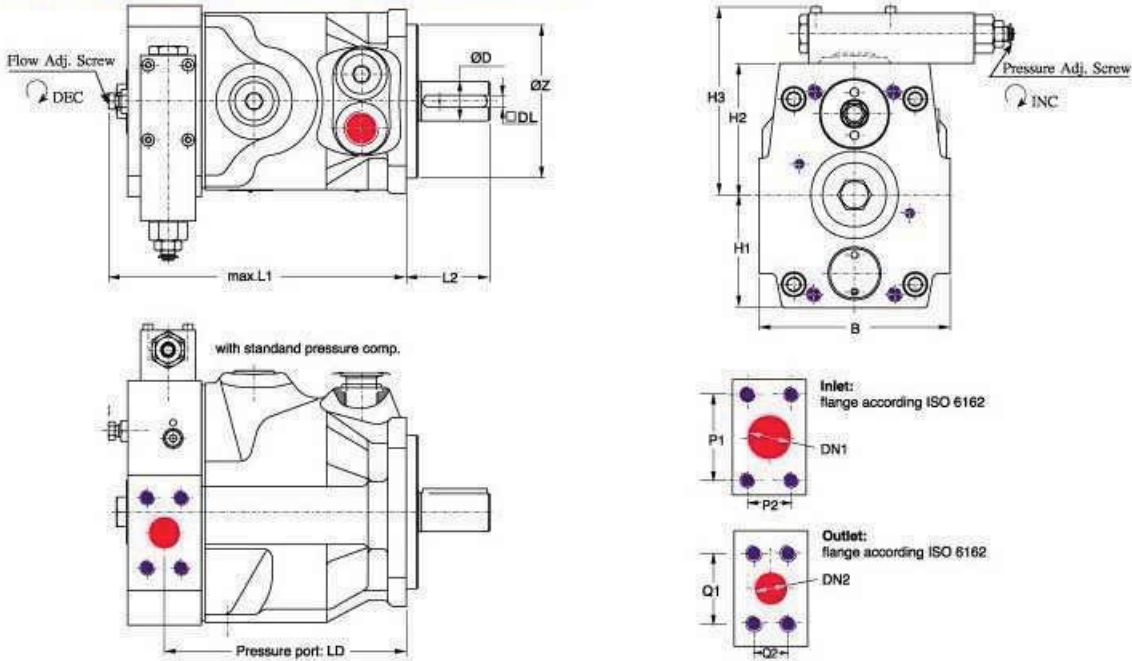

Size Dimension	L1(max.)	L2	B	H1	H2	H3	$\varnothing D$ k6	$\varnothing Z$ h8	LD	DN1	DN2	P1	P2	Q1	Q2	$\square DL$
PV 16/20/23	212	52	132	80	94	140	25	100	170.5	32	19	58.7	30.2	50.8	23.8	8x7x40
PV 32/40/46	245	68	156	92	107	153	32	125	197	38	25	69.9	35.7	57.2	27.8	10x8x56
PV 63/71/80/92	306	92	200	118	135	181	40	160	252	51	32	77.8	42.9	66.6	31.8	12x8x80
PV 140/180	385	92	200	145	158	204	50	160	305	64	32	88.9	50.8	66.6	31.8	14x9x75

### Pump control types & performance curves list

