

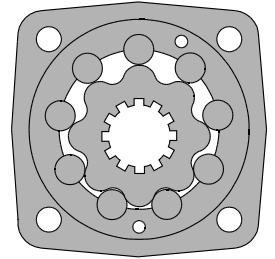

MAV motor have constant working displacement and obtain hightorque at low speed. This type motors puts hydraulic power into work which is expressed in the direct relation between flow rate and speed, pressure, torque.



**Specifications**

TYPE		MAV 315	MAV 400	MAV 500	MAV 630	MAV 800
Displacement (c.c/rev)		333	419	518	666	801
Max. speed (rpm)	Cont	510	490	395	315	240
	Int(3)	630	590	470	375	300
Max. Torque (da Nm)	Cont	92.7	122.3	145	163.8	182
	Int(3)	110.3	144.1	178.6	200.5	211.2
	Peak(4)	135	170.5	212.3	233.8	247.5
Max. output (Kw)	Cont	43.2	45.3	58.6	38.2	35.2
	Int(3)	52	52	52	46	40
Max. pressure drop (bar)	Cont	200	200	200	180	160
	Int(3)	240	240	240	210	180
	Peak(4)	280	280	280	240	210
Max.oil flow (l/min)	Cont	150	170	200	200	200
	Int(3)	220	225	225	225	225
Max. Inlet pressure (bar)	Cont	210	210	210	210	210
	Int(3)	250	250	250	250	250
	Peak(4)	300	300	300	300	300
Weight (kg)		31.8	32.6	33.5	34.9	36.5

(3) Intermittent operation rating applies to 6 sec. of every minute

(4) Peak load rating applies to 0.6 sec of every minute

TYPE		MAV 315	MAV 400	MAV 500	MAV 630	MAV 800
Displacement (in.3/r )		20.3	25.6	31.6	40.6	48.9
Max. speed (rpm)	Cont	448	388	386	224	185
	Int(3)	650	527	428	332	275
Max. Torque (lb-in)	Cont	8204	10824	12833	14496	16107
	Int(3)	9762	12753	15806	17744	18691
	Peak(4)	11948	15089	18789	20691	21904
Max. output (hp)	Cont	57.9	60.7	78.6	51.2	47.2
	Int(3)	69.7	69.7	69.7	61.7	53.6
Max. pressure drop (psi)	Cont	2900	2900	2900	2610	2320
	Int(3)	3480	3480	3480	3045	2610
	Peak(4)	4060	4060	4060	3480	3045
Max.oil flow (gpm)	Cont	40	45	53	53	53
	Int(3)	58	60	60	60	60
Max. Inlet pressure (psi)	Cont	3045	3045	3045	3045	3045
	Int(3)	3625	3625	3625	3625	3625
	Peak(4)	4350	4350	4350	4350	4350
Weight (lbs)		70.11	71.87	73.85	76.94	80.47

**Dimensions and Mounting Data**

Code	Versions		
Port	G (deep)	M (deep)	U (deep)
P(A,B)	2 x G 1 (18)	2 x M33 x 2 (18)	2 x 1 5/16-12UN (18)
T	G 1/4 (12)	M14 x 1.5 (12)	9/16-18UNF (12)
C	4 x M12 (10)	4 x M12 (10)	-

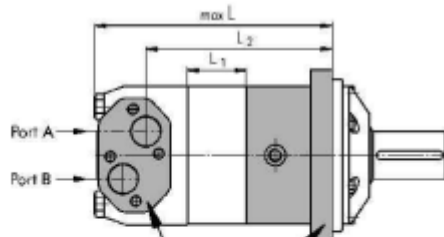

**Porting**

Side Ports  
Versions **G M**

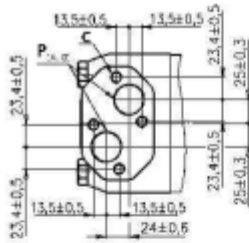

O-Ring Ports  
Versions **U**

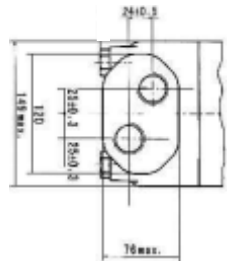

**Mounting**

Square Mount (4 Holes)

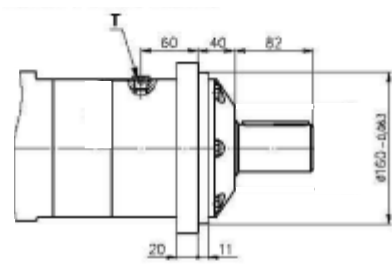

**W** WheelMount

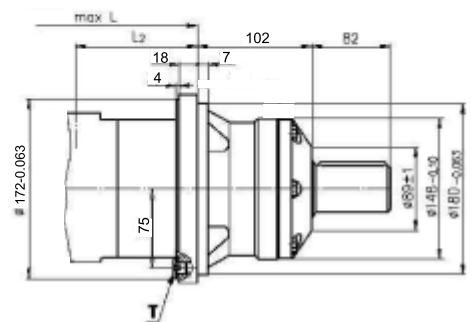

Type	L	L <sub>2</sub>	L <sub>1</sub>
MAV 315	217	161.5	27
MAV 400	224	168.5	34
MAV 500	232	176.5	42
MAV 630	244	188.5	54
MAV 800	255	199.5	65

Type	L	L <sub>2</sub>	L <sub>1</sub>
MAVW 315	148.5	93.5	27
MAVW 400	155.5	100.5	34
MAVW 500	163.5	108.5	42
MAVW 630	175.5	120.5	54
MAVW 800	186.5	131.5	65

**Shaft Extensions for MAV Motor**

**C** -  $\phi 50$  straight, Parallel key A14x9x70

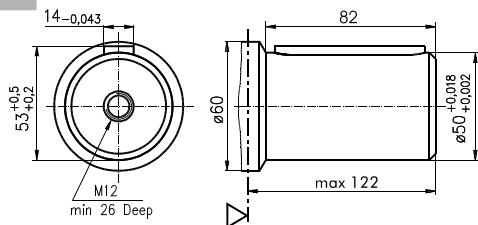

**SH** -  $\phi 2 \frac{1}{8}$ " splined, 16 DP 8/16

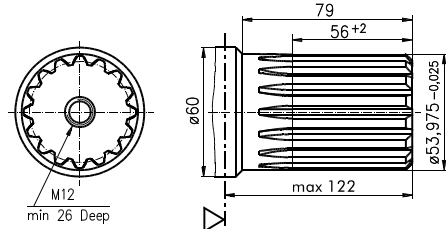

**CO** -  $\phi 2 \frac{1}{4}$ " [57.15] straight, Parallel key 1/2" x 1/2" x 2 1/4"

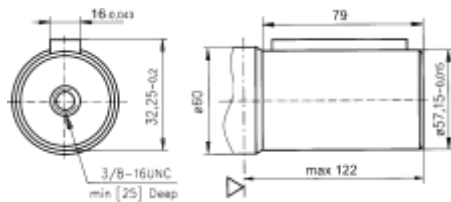

**K** - tapered 1:10, Parallel key B16x10x32

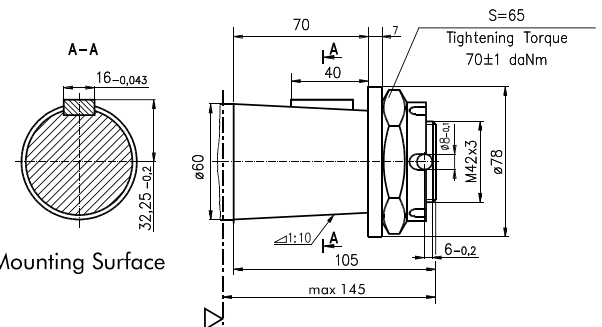

▽ - Motor Mounting Surface

**Permissible shaft seal pressure.**

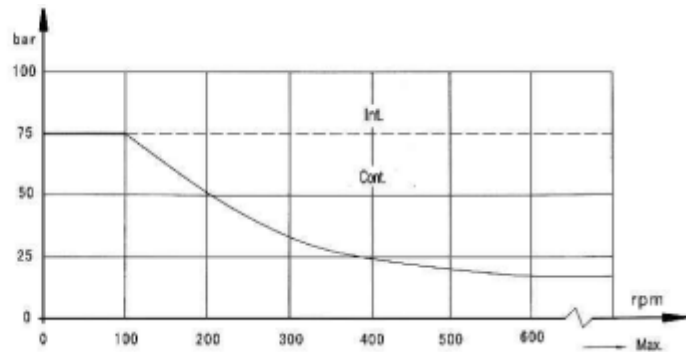
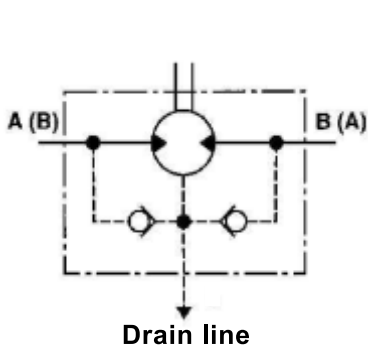

In applications without drain line, output shaft seal exceeds a bit of the pressure in the return line. When applications use the drain line, the pressure of output shaft seal equals the pressure in drain line.

**Shaft Loads**

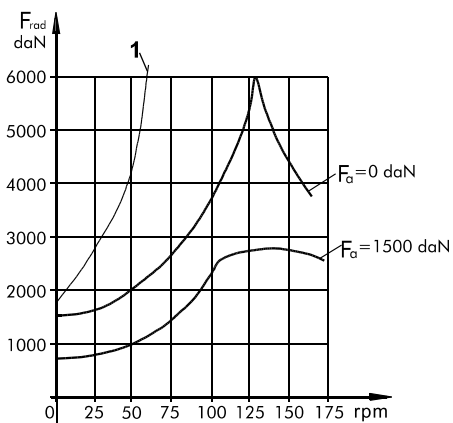

The output shaft runs in tapered bearings that permit high axial and radial forces. Curve "1" shows max. Radial shaft load. Any shaft load exceeding the values quoted in the curve will seriously reduce motor life. The two other curves apply to a B10 bearing life of 3000 hours at 2000 RPM.

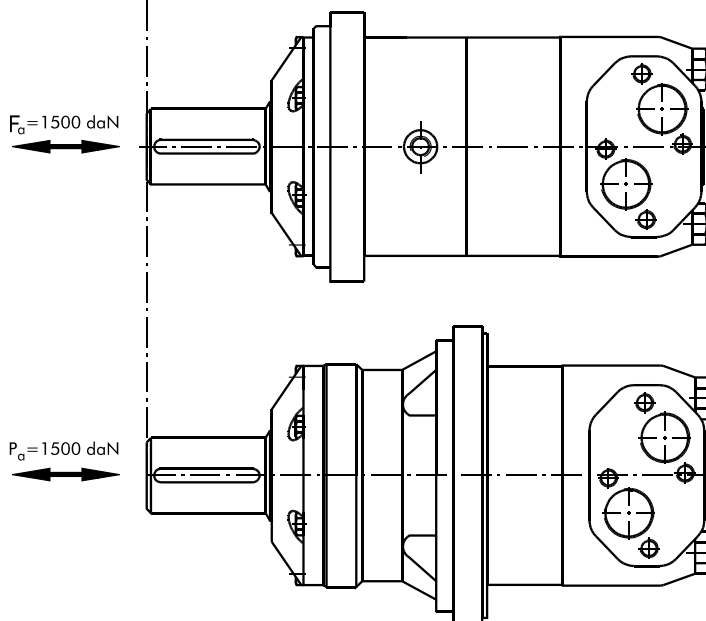

	1	2	3	4	5	6
<b>MAV</b>						

**Pos.1 Mounting Flange**

Omit - Square Mount (4 holes)

**W** - Wheel Mount**Pos.2 Displacement Code****315** - 333cc/19.2 [in.3/r]**400** - 419cc/24.5 [in.3/r]**500** - 518cc/30.5 [in.3/r]**630** - 666cc/38.6 [in.3/r]**800** - 801cc/49.0 [in.3/r]**Pos.3 Shaft Extensions****C** -  $\phi$  50 Straight, Parallel key A14 x 9 x 70**CO** -  $\phi$  2 1/4" [57.15] Straight, Parallel key 1/2" x 1/2" x 2 1/4"**K** - Tapered 1:10, Parallel key B16 x 10 x 32**SH** -  $\phi$  2 1/8" Splined 17T**Pos.4 Porting**

Omit - G1

**M** - Metric**U** - 2 x 15/16 - 12UN**Pos.5 Painting**

Omit - Grey

**B** - Black**00** - No Paint**Pos.6 Rotation**

Omit - Standard Rotation

**R** - Reverse Rotation