

POWER PACK COMPONENTS & ACCESSORIES

STEEL TANKS

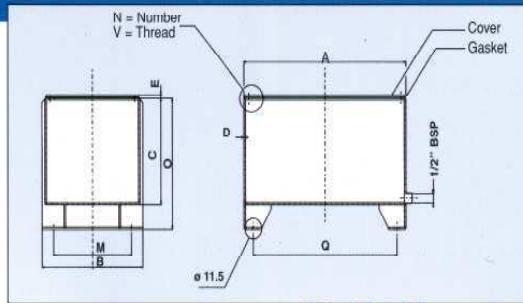

Steel hydraulic tanks

Steel lid and gasket

Pad for level indicator

Drain plug

Inspection covers and aluminium tanks available

Complete	Oil Tank	Gasket	Cover	Capacity dm ³	Dimensions (mm)										Cover fixing	
					A	B	C	D	E	M	O	Q	N	V		
CF 12 C	CF 12	GS 12	CCF 12	14	335	270	235	2	4	208	290	285	6	M8		
CF 16 GC	CF 16	GS 16	CCF 16	22	410	325	250	2	4	270	305	364	6	M8		
CF 30 GC	CF 30	GS 30	CCF 30	39	470	375	280	2	4	312	335	428	8	M8		
CF 55 GC	CF 55	GS 55-75	CCF 75	58	600	470	310	2.5	4	401	365	548	10	M8		
CF 75 GC	CF 75	GS 55-75	CCF 75	75	600	470	400	2.5	4	401	455	548	10	M8		
CF 100 GC	CF 100	GS 100	CCF 100	100	675	520	450	2.5	4	455	505	625	10	M8		
CF 180 GC	CF 180	GS 180	CCF 180	165	805	620	500	2.5	4	555	555	755	10	M8		

Aluminium drive couplings and bellhousings

STANDARD 4 BOLT EUROPEAN GEAR PUMP PART N^{OS}

MOTOR FRAME	4 POLE POWER REQ.		PUMP	BELL DRIVE HOUSING No.	COUPLING No.
	KW	HP			
D63	0.12-0.18	0.16-0.25	0.5	LS140	NDO1
D63	0.12-0.18	0.16-0.25	1	LS141	NDO3
D71	0.25-0.37	0.35-0.5	0.5	LS160	ND1A
D71	0.25-0.37	0.35-0.5	1	LS161	ND2
D80	0.55-0.75	0.75-1	0.5	LS210	ND4C
D80	0.55-0.75	0.75-1	1	LS201	ND5
D80	0.55-0.75	0.75-1	2	LS203	ND7
D80	0.55-0.75	0.75-1	3	LSE206	ND50A
D90	1.1-1.5	1.5-2	1	LS201	ND8
D90	1.1-1.5	1.5-2	2	LS203	ND10
D90	1.1-1.5	1.5-2	3	LSE206	ND51A
D100/112	2.2-4	3-5.5	1	LS250	ND11
D100/112	2.2-4	3-5.5	2	LS253	ND61
D100/112	2.2-4	3-5.5	3	LS255	ND15
D132	5.5-9	7.5-12.5	2	LS300	ND16
D132	5.5-9	7.5-12.5	3	LS302	ND17
D160	11-15	15-20	2	LS350	ND43A
D160	11-15	15-20	3	LS352	ND43C
D180	18.5-22	25-30	2	LS350	ND44A
D180	18.5-22	25-30	3	LS352	ND44C
D200	30	40	3	LSE401	ND40
D200	30	40	3.5	LSE405	ND41
D225	37-45	50-60	3	LS456	ND32
D225	37-45	50-60	3.5	LS451	ND30



Motor pump units

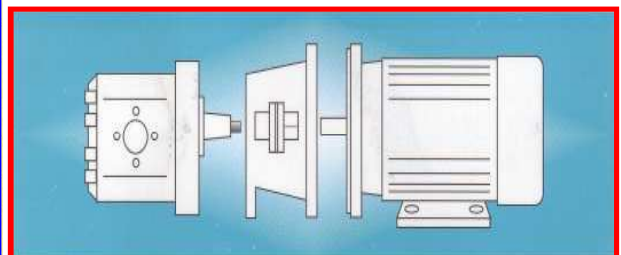

POWER PACK COMPONENTS & ACCESSORIES



TANK TOP RETURN LINE FILTERS

3, 10, 25 Micron elements
Visual or electrical indicators

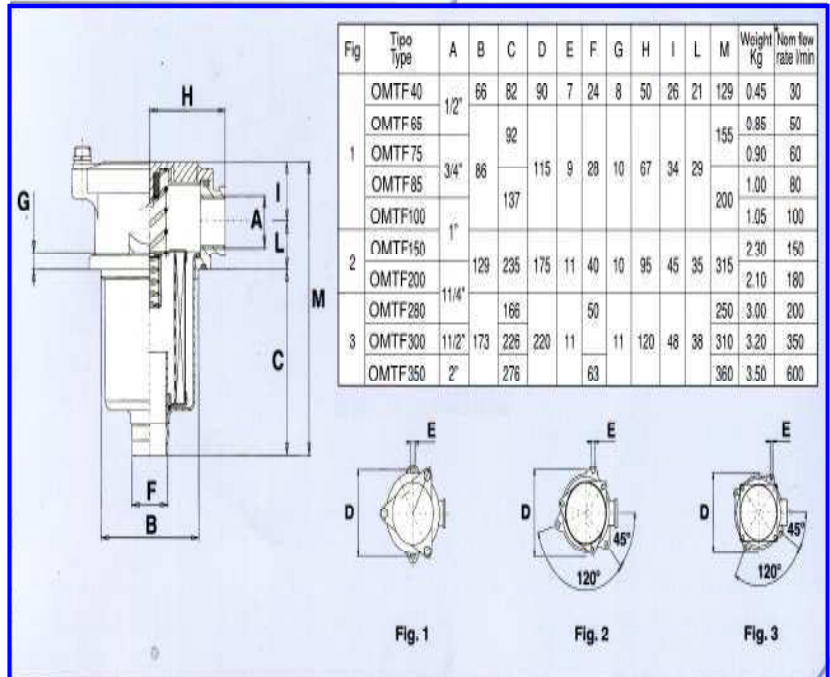

"Spin on" suction and return line filters

Part No:	Micron	Thread (BSP)	Replacement Element
RHPI-05 - GNR	10	3/4	CS05GN
RHPI-05 - BNR	25	3/4	CS05BN
RHPI-05 - ENR	125	3/4	CS05EN
RHPI-10 - GNR	10	1/4	CS10GN
RHPI-10 - BNR	25	1/4	CS10BN
RHPI-10 - ENR	125	1/4	CS10EN
RHPI-20 - GNR	10	1/2	2xCS10GN
RHPI-20 - BNR	25	1/2	2xCS10BN
RHPI-31 - GNR	10	SAE	2xCS10GN
RHPI-31 - BNR	25	SAE	2xCS10BN



Aluminium head - Steel canister - Nitrile seals

Visual or Electrical clogging indicators

Max pressure 12 bar - Bypass 1.7 bar - Temp rang 25+95 deg c

POWER PACK COMPONENTS & ACCESSORIES



TIPO TYPE	Filtro aria - Air Filter FiltraZIONE micron	Flusso raccomandato dm ³ /min*	DIMENSIONI - DIMENSIONS (mm)						Fori fissagg. Fixing holes
			A	B	C	D	E	F	
TR-1-B	40 SPUGNA	250	47	34	52	65	27	41	3
TR-2-B						80			
TR-3-B						150			
TR-4-B						203			
TR-1-B-S10	10 SPUGNA	700	80		83	150	50	73	6
TR-2-B-S10						80			
TR-3-B-S10						150			
TR-4-B-S10						203			
TR-1-B-P10	10 CARTA	250	47	34	52	65	27	41	3
TR-2-B-P10						80			
TR-3-B-P10						150			
TR-4-B-P10						203			

FILLER BREATHER

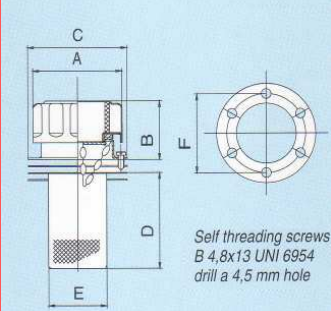

Filler caps with air breathers
Chrome or plastic
Complete with gaskets, screws and baskets

Visual level gauges
With or without thermometer
76mm - 127mm - 254mm

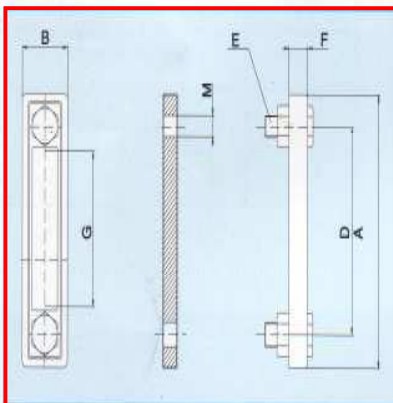

Tipo Type	Dimensioni - Dimension (mm)						
	A	B	F	G	D	E	M
LG1	116	39	16	40	76	M10	10,5 11
LG1T							
LG1-M12	116	39	16	40	76	M12	10,5 11
LG1T-M12							
LG2	177	48	18	127	127	M12	12,5 13
LG2T							
LG2-M10	177	48	18	127	127	M10	12,5 13
LG2T-M10							



Suction strainers 3/8 bsp - 3 bsp
90 - 125 - 250 micron
Primarily for fitting inside the reservoir



Other accessories : Gauges, Pressure filters,
Coolers, Tank top flanges, Diffusers,
Foot brackets and Gaskets.